

Häny Mixing and Injection Technology

Compact Grout Plant IC 1100/725



The compact grout plants consist of the proven, standard Häny components of a mixer, agitator, and grout pump. This setup is suitable for a wide range of applications such as anchoring, sleeve pipe, contact, and backfill grouting. For higher outputs and increased quality control, the plants are also available in semi-automated and fully automated versions.

HÄNY

Mixing and Injection Technology

Compact Grout Plant

IC 1100/725

Key features

- ▶ Extremely compact mixing and injection system with central lifting point for easy transport and minimum installation time
- ▶ High productivity due to ergonomically positioned operating elements
- ▶ High reliability and low-maintenance operation with good accessibility to the wear parts
- ▶ Independent of pressure ratios, the suction stroke is always carried out at high velocity in order to flush the valves and to avoid clogging

Typical applications

- ▶ Grouting of anchors, soil nails, tension cables as well as for sleeve pipe, rock, and contact injections
- ▶ Preparation and pumping of bentonite suspensions for pipe jacking and microtunneling

Pump performance

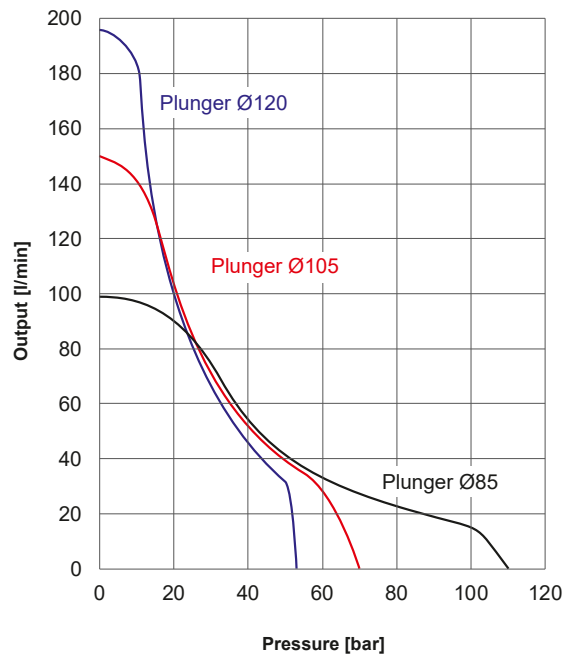

Grout pump

ZMP 725

Capacity IC ¹ :	5 m ³ /h
Max. pressure:	100 bar
Max. aggregate size:	8 mm
Hydraulic tank:	140 l
Pump module:	double
Cooling water flow rate:	5–6 l/min
Cooling water connection:	BSP ½"
Pressure connection:	BSP 2"

Included as standard

- Manual pressure and flow control
- Oil level and temperature sensor

Optional

- Pressure relief valve Grout pump - Agitator, manual
- Low pressure control cartridge

¹ Water to cement ratio = 1

Mixer / Agitator

Usable content mixer:	260 l
Circulation capacity:	1,400 l/min
Water connection:	BSP 1"
Holding capacity agitator:	800 l

Optional

- Auxiliary mixing unit (recommended for W/C < 0.45)
- Automatic water meter 1"

Control

PLC with stroke counter
Lockable main switch, emergency stop
Mixer ON-OFF
Agitator ON-OFF
Pump ON-OFF

Optional

- Remote control with 50 m cable, ON-OFF
- P/Q-Registration



Electrical data

Tension:	3x 400/460
Frequency:	50 / 60 Hz
Nominal power:	19 / 22 kW

Weight and dimensions

Total weight:	1,575 kg
Width:	1,950 mm
Height:	1,900 mm
Length:	2,192 mm

Construction and dimensions

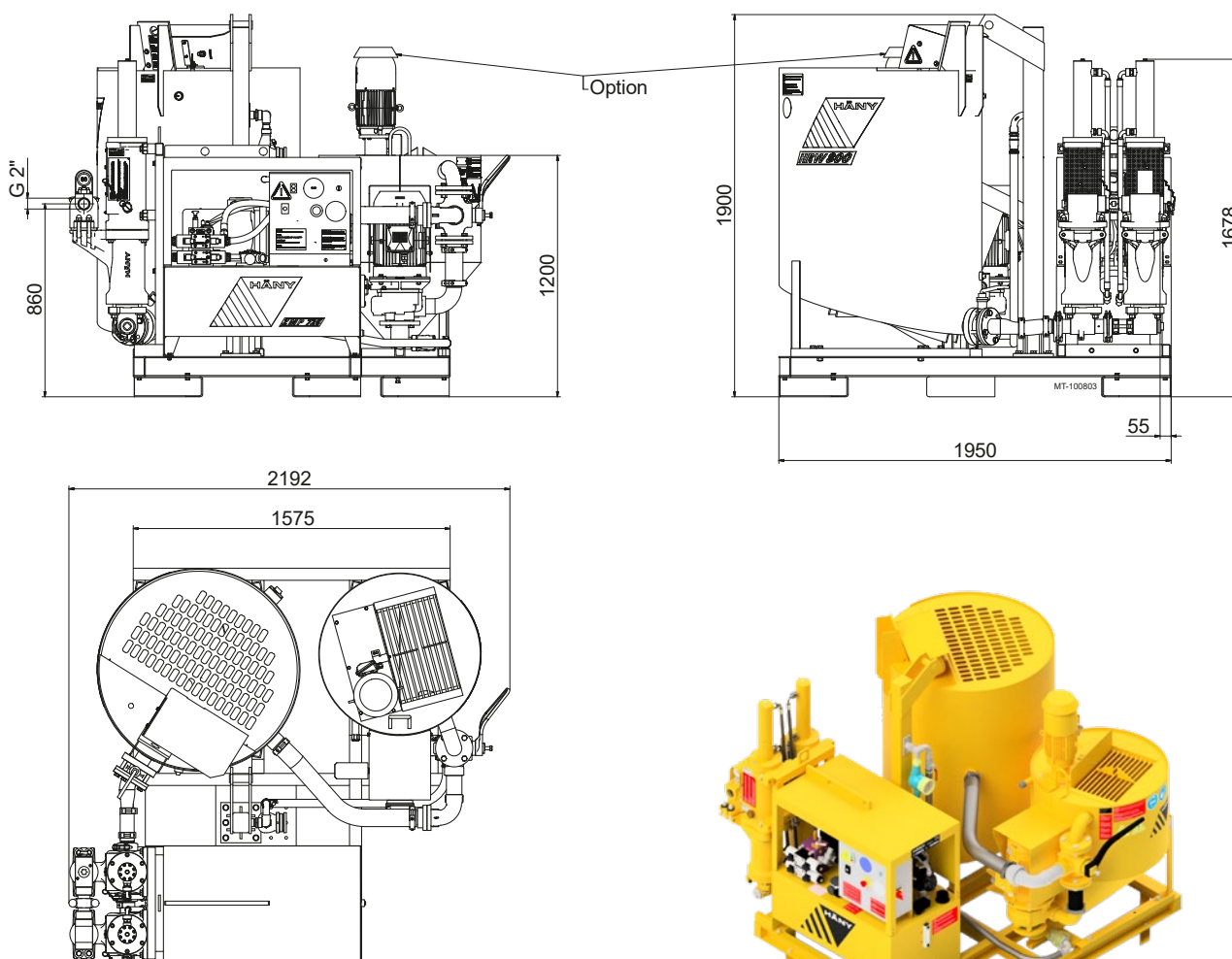

Document No. PM2-102016 00/08:18. Legal Notice © Copyright 2018, Häny AG, Jona/Switzerland. Any unauthorized use or copying of the contents or any part hereof is prohibited. Illustrations and photos may show equipment with optional extras. No warranty is made regarding specifications or otherwise. Specifications and equipment are subject to change without notice.



Mixing and Injection Technology

Häny Austria GmbH | Packerstraße 133a | AT-8561 Söding - St. Johann
Tel. +43 (0) 3137/46 450 | office@haeny.com | www.haeny.at