

Häny Mixing and Injection Technology

# Automated Grout Plant FAIC 650/725



The compact grout plants consist of the proven, standard Häny components of a mixer, agitator, and grout pump. In its automated execution the plant provides enormous savings in terms of personnel costs, high production outputs, quality monitoring and enhanced working conditions.



**HÄNY**

Mixing and Injection Technology

# Automated Grout Plant

## FAIC 650/725

### Key features

- ▶ Extremely compact mixing and injection system with central lifting point for easy transport and minimum installation time
- ▶ High production output, quality monitoring and cost savings in terms of personnel costs due to fully automated mixing process
- ▶ Precise dosing of individual components is guaranteed by a sophisticated weighing system in the mixer (typical feed of dry components via silos/screw)
- ▶ Mixing recipes can be entered and selected via touch screen as required
- ▶ Batch records of each mixing cycle with consumption records (total of consumed components) is stored and can be transferred via a USB interface

### Typical applications

- ▶ Grouting of anchors, soil nails, tension cables as well as for sleeve pipe, rock, and contact injections
- ▶ Preparation and pumping of bentonite suspensions for pipe jacking and microtunneling

### Pump performance

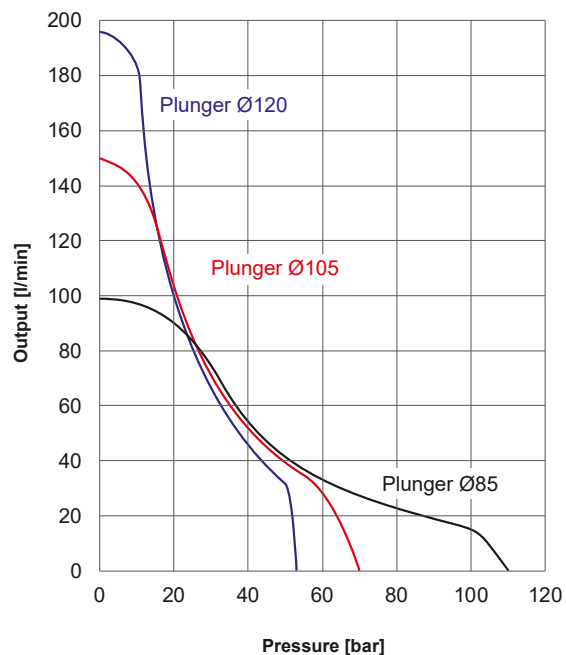

### Grout pump

### ZMP 725

Capacity FAIC <sup>1</sup> :	5 m <sup>3</sup> /h
Max. pressure:	100 bar
Max. aggregate size:	8 mm
Hydraulic tank:	140 l
Pump module:	double
Cooling water flow rate:	5–6 l/min
Cooling water connection:	BSP ½"
Pressure connection:	BSP 2"

### Included as standard

- Manual pressure and flow control
- Oil level and temperature sensor

<sup>1</sup> Water to cement ratio = 1

### Mixer / Agitator

Usable content mixer:	260 l
Circulation capacity:	1,400 l/min
Water connection:	BSP 1"
Holding capacity agitator:	350 l

### Optional

- Auxiliary mixing unit (recommended for W/C < 0.45)

### Control

PLC weigh batch control with touch screen
Recipe management
Automated mixing cycle ON-OFF
Pump ON-OFF

### Optional

- Remote control ON-OFF
- P/Q-Registration



### Electrical data

Tension:	3x 400/460 V
Frequency:	50 / 60 Hz
Nominal power:	19 / 22 kW

### Weight and dimensions

Total weight:	1,950 kg
Width:	2,031 mm
Height:	1,992 mm
Length:	2,156 mm

### Construction and dimensions

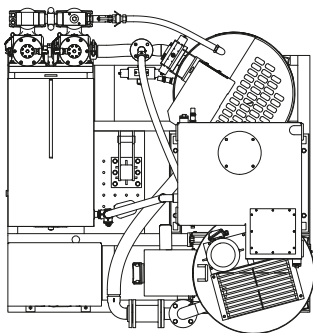
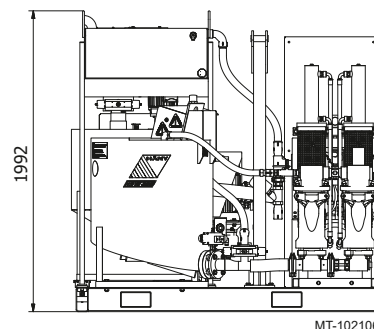
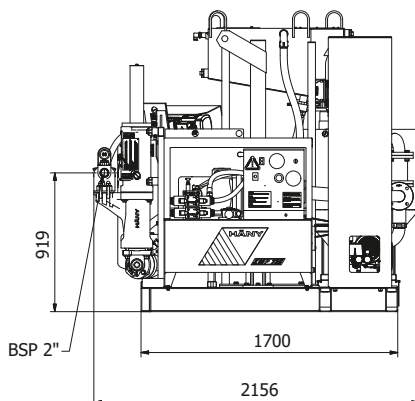
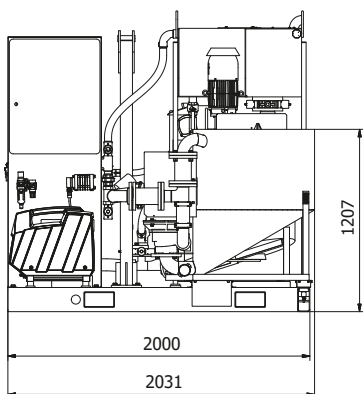

Document No.: PW2-102155.00/01\_19. Legal Notice © Copyright 2019, Häny AG, Jona/Switzerland. Any unauthorized use or copying of the contents or any part hereof is prohibited. Illustrations and photos may show equipment with optional extras. No warranty is made regarding specifications or otherwise. Specifications and equipment are subject to change without notice.



**HÄNY**

Mixing and Injection Technology

Häny Austria GmbH | Packerstraße 133a | AT-8561 Söding - St. Johann  
Tel. +43 (0) 3137/46 450 | office@haeny.com | www.haeny.at